

Rapid - Release™

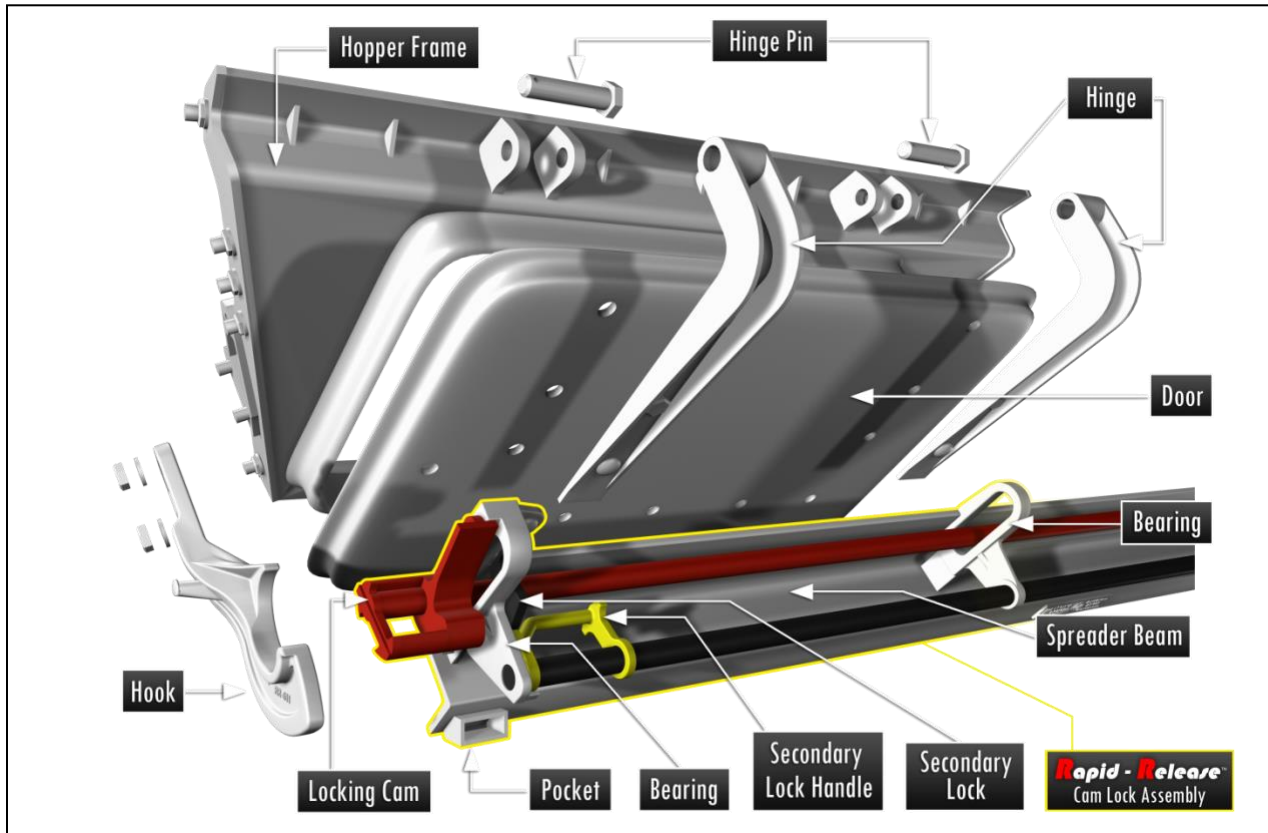

Door Size	Floor Slope	Hopper Frame P/N	Left Hook	Right Hook	RR Cam Lock Assembly P/N
Narrow	30 degree	HF-259/216	DA-00611, RR-611-L	DA-00612, RR-611-R	DA-00640-1
Wide	30 degree	HF-212	DA-00651, RR-651-L	DA-00652, RR-651-R	DA-00642-1
Wide	45 degree	HF-238	DA-00659, RR-659-L	DA-00660, RR-659-R	DA-00642-1

Rapid - Release is D. A. International Casting Company's most advanced WINE manual door lock system and it offers the following advantages:

- ✓ Designed using the same technology as the proven single door cam lock system, but requires fewer parts than that of a pair of single door cam locks.
- ✓ One person can operate a pair of hopper doors from either side of the rail car.
- ✓ Easy to install on new or existing conventional hopper cars.
- ✓ Built WINE tough and features dual outboard hooks to help support the commodity more evenly.
- ✓ This patented design features over-center locking cams which are self locking when the car is loaded.
- ✓ A secondary lock is built in for added safety and as a provision to operate in rotary dump service.